

All this information will be available for download on the Hudson Technologies website. Each customer will have a secured login and password for personal access.

We will even take this product a step further. At no additional cost, we will track changes in Chiller Chemistry™ and the chiller performance over predetermined periods of time to identify potential problems before they become critical and catastrophic to the system.

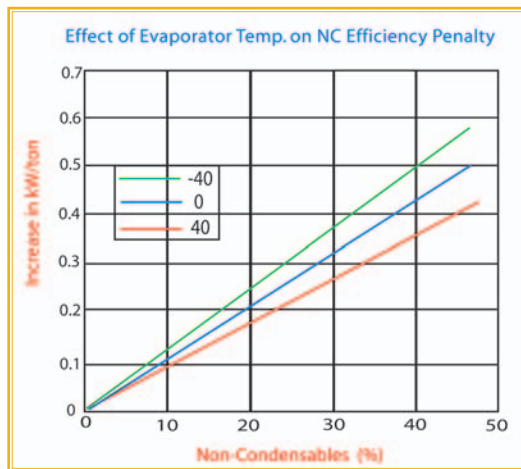

BENEFITS OF ChiISMART™

Some major benefits that result from the packaged approach include:

- System optimization - better and reliable system operation
- Identification of potential energy and cost savings and reduced environmental emissions
- Detailed information of contaminants such as oil, moisture, non-condensables, acid, chlorides
- Base-lining and trending of chiller performance over time and its relationship with Chiller Chemistry™
- Avoided costs and loss of revenues due to unplanned shutdowns for equipment maintenance and repairs
- Development of a "Preventative & Predictive" approach lowering current maintenance costs.

Typically, for facilities with multiple chiller systems, 20% of the chiller systems result in 80% of the system efficiency loss. ChiISMART™ will identify these units allowing the owner to rectify the situation.

WHY HUDSON TECHNOLOGIES?

Hudson Technologies is the only company in the industry that provides an extensive depth of engineering and chemistry know-how. This allows Hudson to solve problems related to refrigerants, oil and other fluids and find solutions to the most mission critical situations. Over the past decade, Hudson has uncovered many new findings about refrigerants, oil and other fluids and their impact on system performance. Part of our mantra is to never be complacent and to strive for better solutions that benefit our customers.

Hudson has offered their Chiller Chemistry™ and Performance Evaluation services to several commercial and industrial customers. We have shown time and again, the high value that a customer receives in return for a minimal upfront cost. The addition of the new packaged approach to Hudson's already existing RefrigerantSide® Service program makes it the most effective service in the world aiding in the operation and maintenance of the customer's chiller/refrigeration systems at the highest levels of energy efficiency and reliability.

For an example of ChiISMART™, visit www.hudsontech.com/chillsmart.com
Use login name "guest" and password as "chillsmart" and follow the links.

For additional information contact your Account Executive at 800-501-HDSN or email chillsmart@hudsontech.com

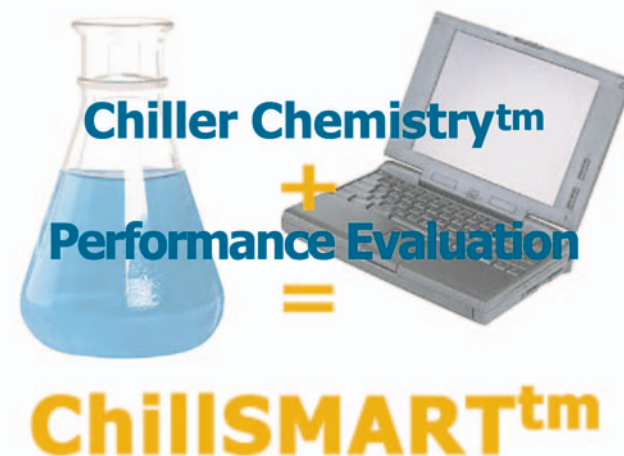

3 EASY STEPS:

1. *Collect refrigerant & oil samples with our easy-to-use kits*
2. *Complete chiller operating data form*
3. *Mail samples & email/fax data form back to us*

CHILLER CHEMISTRY™

Chiller Chemistry™ is the study of the interrelationships between refrigerants, oil, other fluids and all types of contaminants and their affects on the performance of chillers, cooling equipment and refrigeration systems. It provides the best-in-class solutions to address refrigerant/contaminant related problems.

Current sampling programs offered by others fall short in providing value to the owners of chillers. The value we offer is an integrated approach that combines the test results of refrigerant, oil and all other fluids. While taking individual samples is far from new, we have added important elements such as the individual and collective interpretation of the test results followed by recommendations based on our extensive engineering and chemistry background.

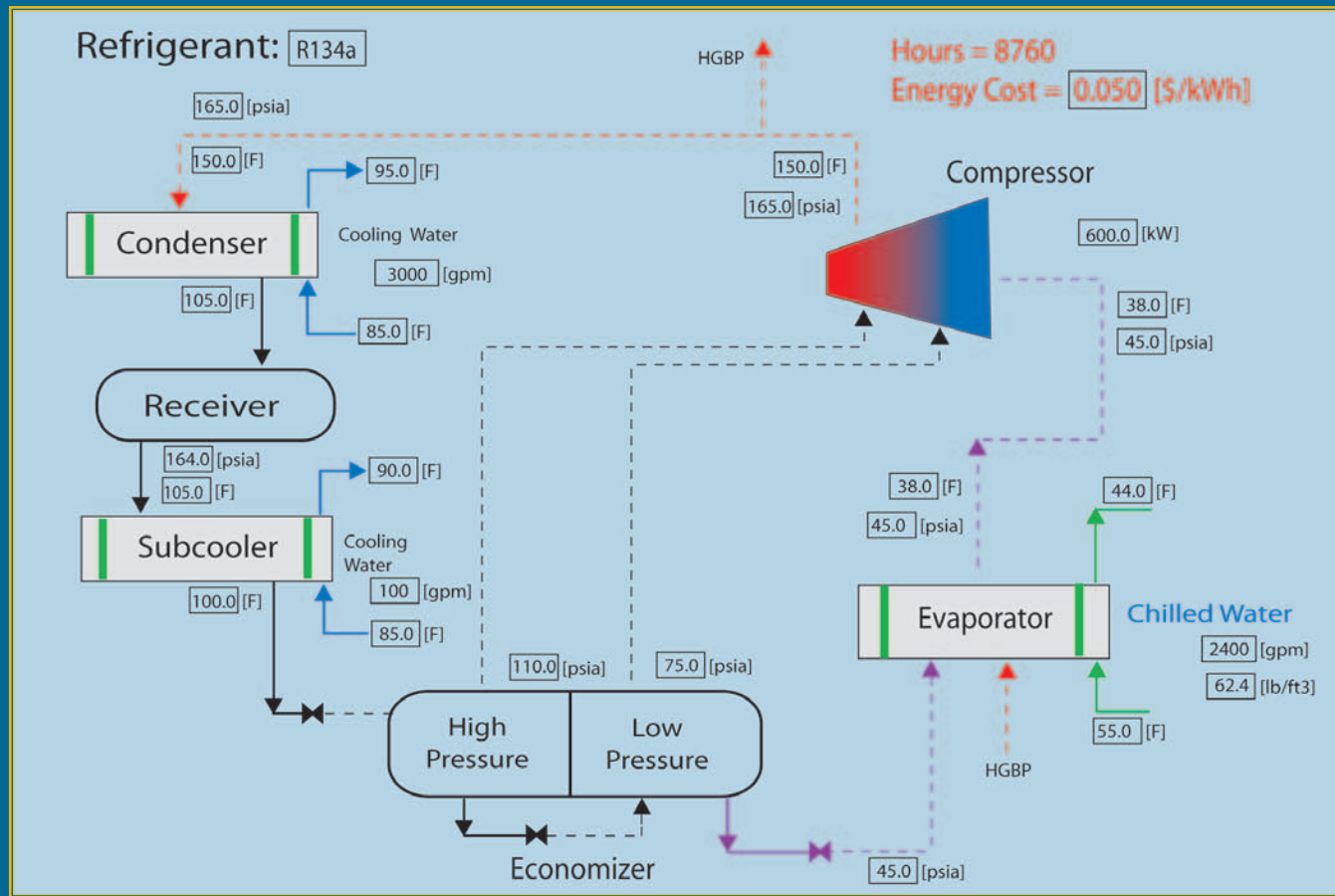

PERFORMANCE EVALUATION

Performance Evaluation is a detailed engineering analysis of the actual performance of the chiller system including the individual components creating a snapshot of the actual operation.

Detailed thermodynamic system analysis models will be used to evaluate the performance of the system. Performance Evaluation results will be presented in a graphical manner and include:

- Chiller system efficiency
- Potential energy & cost savings
- Heat Exchanger performance
- Compressor performance
- Electric motor, steam turbine, gas-fired engine performance

THE CHIISMART™ APPROACH

ChiISMART™ offers both Chiller Chemistry™ and Performance Evaluation as a Packaged Approach.

ChiISMART™ includes:

- A complete chemistry and engineering-based written review that compares and correlates the relationship between the fluid samples
- Performance evaluation results
- An interpretation report of the findings, interrelationships and recommendations for remedy
- A certificate of analysis